



Powering Innovation



PROTECTION + AUTOMATION + CONTROL

# TWO STAGE NEUTRAL UNBALANCE CURRENT RELAY JRC 124

**JVS ELECTRONICS PVT. LTD.**

#121, Manchanayakanahalli,  
Bangalore Mysore Highway, Bidadi,  
Ramanagara District - 562 109, Karnataka, India  
+91 94808 26272, +91 94808 26260  
bangalore@jvselectronics.in, www.jvselectronics.in

## FEATURES

- ◆ Software based design
- ◆ Instantaneous/Definite time
- ◆ Insensitive to harmonics
- ◆ Wide setting ranges
- ◆ Trip test facility

## APPLICATION

Neutral unbalance current protection of double star capacitor banks with floating neutral.



## PRINCIPLE OF OPERATION

The sensing current is converted to voltage by an internal resistor and this voltage is fed to a harmonic network which is tuned to fundamental frequency. The output of filter is fed to voltage comparator. When the sensing current signal at the fundamental frequency exceeds the set value, the comparator gates a train of pulses to the processor. The program residing in the CPU performs the function of control and also gives output signals for relay and LED driver circuits. The operation of the relay is indicated by the glowing of a 'Red' LED, which has to be reset manually by means of a 'RESET' push button provided on the front of the relay. A 'Trip Test' push button is also provided in the relay to enable testing of the trip and alarm circuits. When this push button is pressed, the output element of the relay is energized and its contacts close to energize the trip and alarm circuits.

## TECHNICAL DATA RATING

Current rating (In)	:	1A/5A
Aux. Supply	:	1) 20 to 60V DC
	:	2) 75V to 150V AC/DC
	:	3) 175 to 300V DC & 185 to 250V AC

## SETTINGS

Setting range (for Stage 1 and 2)	:	2.5% to 80% of rated current in steps of 2.5%.
Instantaneous	:	Less than 40 milliseconds.
Definite time (for Stage 1 and 2)	:	0 to 25 seconds adjustable in steps of 0.1 second.
Rejection ratio of 3rd harmonic to fundamental frequency	:	25 : 1. The relay will not operate at third harmonic currents up to 25 times the setting.

## OVER LOAD RATINGS

AC current input	:	2 times Rated continuous
	:	20 times Rated for 3 secs.

## BURDEN

AC current input	:	0.65VA at Rated 5A
	:	0.2VA at Rated 1A
Aux. Supply	:	Less than 6W

**ACCURACY**

- Operating value : ±5%
- Drop-off / pick-up : Between 80% to 95%
- Operating Time : ±5% or ±30ms whichever is higher

**CONTACT RATINGS**

- Relay rating : 10A at 24V DC/230V AC
- Contacts configuration : 2 C/O contacts

**CONTACT DURABILITY**

- Loaded contact : 10,000 operations min.
- Unloaded contact : 1,00,000 operations min.

**INSULATION**

1. 2 KV RMS, 50 Hz for 1 minute 2.5 KV for 1 sec. Between all terminals and cases .
2. 1 KV RMS, 50 Hz for 1 minute across open contacts

**MECHANICAL DESIGN**

- Weight : 750 gms. (approx)
- Case Size : 144sq mm, depth 117 mm
- Installation : Flush mounting
- Panel cutout : 138mm x 138mm

**STANDARD COMPLIANCE**

- Accuracy Test : IEC 60255-3
- Insulation Test : IEC 60255-5

**TERMINAL DIAGRAM :**

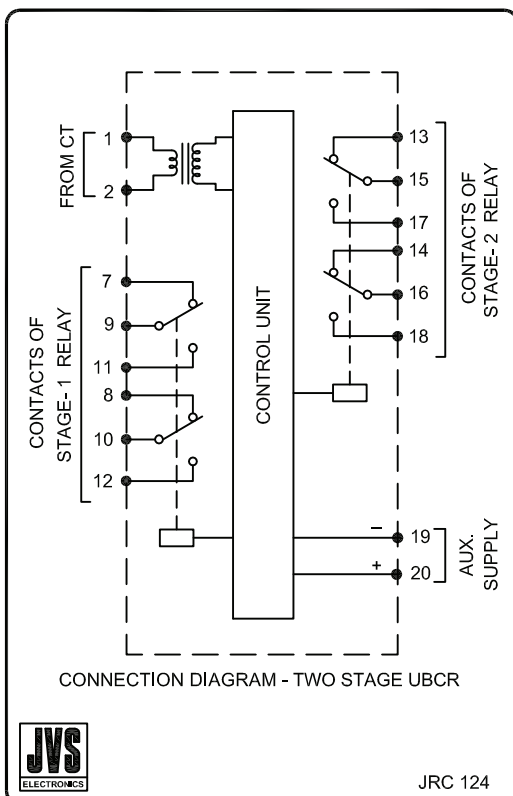

**ORDERING INFORMATION**

- Relay type : JRC 124 (Two Stage)
- Current rating : 1A or 5A
- Auxiliary supply : 1) 20 to 60V DC  
 2) 75 to 150V AC/DC  
 3) 175 to 300V DC/185 to 250V AC